

07-0486-0
615.478.5
Япония
08-1

ОТДЕЛ
ПРОМЫШЛЕННЫХ
КАТАЛОГОВ ВНИИПМ

Blood Bank Refrigerator

- Visual and audible alarm system
- Double pane glass window door
- HFC refrigerant

SANYO

MBR-304D/304DR

MBR-304G/304GR



MBR-304DR

Знахарь - 99



MBR-304D/304DR/304G/304GR

Features

• Visual and audible alarm system

- Temperature and power failure
- Remote alarm contact

• Double pane glass window

- Low thermal leakage door with double pane glass window
- Low power consumption and quiet operation

• HFC refrigerant

- HFC refrigerant with current oil and CFC-Free insulation

• Capacity

- Storage capacity: 450ml bag × 120 pieces (24 bags × 5 drawers)

- Effective capacity: 302 liters (10.6 cu.ft.)(D/R/GR)
- 304 liters (10.7 cu.ft.)(D/G)

• Temperature recorder type

- MBR-304D/DR: Slip chart type recorder (MTR-0620LH)
- MBR-304G/GR: Circular chart type recorder (MTR-G04)

Pull-down characteristics

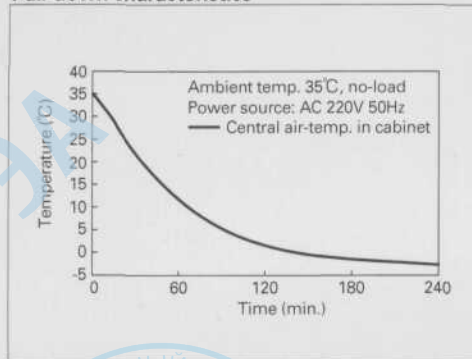

Pull-up characteristics during power failure

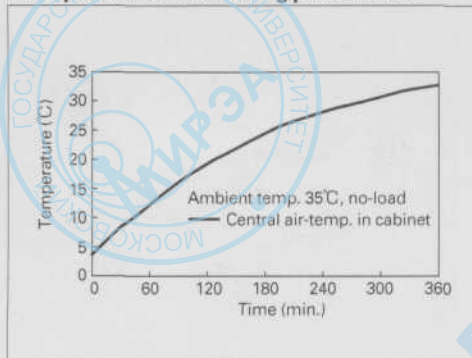

Specifications

Exterior dimensions (W×D×H)	600×680×1,835 (mm) 23.6"×26.8"×72.2" (inch)
Interior dimensions (W×D×H)	520×490×1,150 (mm) 20.5"×19.3"×45.3" (inch)
Effective capacity	302 liters (10.6 cu.ft) (D/R/GR) 304 liters (10.7 cu.ft) (D/G) (120 bags (450ml))
Exterior cabinet	Baked-on acrylic finish galvanized steel
Interior cabinet	Baked-on acrylic finish galvanized steel
Cabinet insulation	CFC-free Rigid polyurethane formed-in-place
Outer door	1 Backed-on acrylic finish galvanized steel Double pane glass window
Inner door	2 (Acrylic)
Door lock	1
Drawers/ Shelves	5 roll out drawers (Stainless steel) (D/R/GR) 4 steel wire shelves, 1 Stainless steel plate (D/G)
Casters	4
Adjustable leveling feet	2
Cooling Performance	4°C (Ambient temperature 35°C)
Air circulation	Forced air
Evaporator	Fin and tube
Defrost	Fully automatic
Condenser	Fin and tube
Compressor	175 W (1/5 HP) Hermetic type
Refrigerant	R-134a
Standard voltage	110V, 60Hz, 1ø, 2.6A 115V, 60Hz, 1ø, 2.3A 220V, 60Hz, 1ø, 1.1A 220V, 50Hz, 1ø, 1.3A 230V, 50Hz, 1ø, 1.4A 240V, 50Hz, 1ø, 1.5A
Rated power consumption	220W
Temperature control	Electronic ON-OFF control Set point 4°C or 5°C Sensor Thermistor
Temperature display	LED (Red) 0.1°C graduation Display range: -9.9°C to 50.0°C
Temperature recorder	MTR-0620LH (D/DR) Recording range: -6°C to 20°C MTR-G04 (G/GR) Recording range: -10°C to 40°C
Monitor and alarm system	250ml monitor bottle × 2 Set point ±2°C (Digital readout adjustable 0.1°C graduation) Auto-reset visual and audible Remote alarm contact Door ajar
Power failure alarm	24hour buzzer and lamp Automatic rechargeable battery
Remote alarm contact	DC30V 2A normal open Temperature alarm or power failure
Monitor bottle	250ml
Lighting	Fluorescent lamp Door switch and control panel switch

Accessories

Door lock key: 1 set

Option

Recording paper: RP06 (D/DR)
RP-G04 (G/GR)
Temperature monitor system

*Specifications subject to change without notice

Dimensions

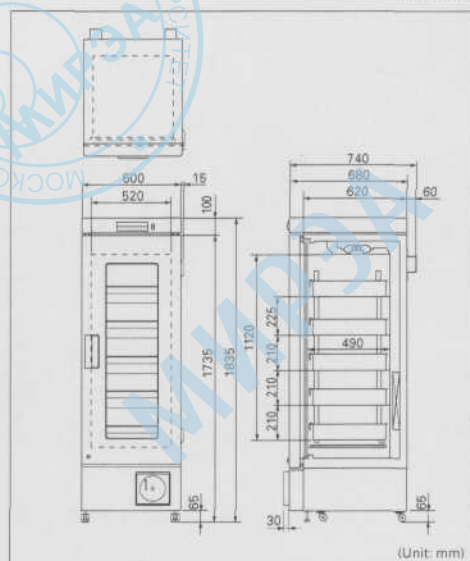
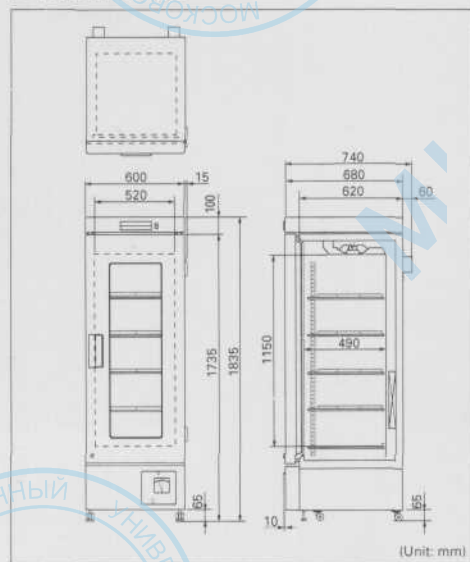

Registered number : JET-0035

Issued date : 1996.8.30

Registered firm : Refrigeration Business Headquarters Refrigerating Products Division

Applicable standard : ISO 9001 : 1994 / JIS Z 9901 : 1994

Applicable scope : Design/Development, Manufacturing and Servicing of Preservation equipments, Culturing equipments, Drying & Sterilizing equipments, Experiment & Environment equipments, Preparation equipments of Medicine and Environmental testing equipments

Distributed by :

SANYO

SANYO Electric Co., Ltd.
SANYO Electric Trading Co., Ltd.
5-15, Hiyoshi-cho 2-chome, Moriguchi-city Osaka, Japan
Telephone: 81-6-992-1521
Fax: 81-6-992-1406 (GII, GIII)
©1999 SANYO Printed in Japan '99. 2. S1.